

Datasheet

SPRINT-Nav



SPRINT-Nav is the world's highest performing all-in-one hybrid navigator for all subsea vehicles and survey operations.

SPRINT-Nav is a turn-key solution combining carefully selected inertial sensors, a Syrinx Doppler Velocity Log (DVL + ADCP) and a high accuracy pressure sensor into a single housing.

The result is not only the highest performing hybrid navigator but also one of the smallest navigation instruments on the market.

All onboard sensors are optimally integrated to provide seamless operation and unprecedented levels of performance compared with standalone instruments from different vendors.

The unit comes pre-calibrated and requires no additional calibration to achieve unprecedented performance with minimal operational complexity.

Each DVL transducer is fitted with a full depth-rated water block to ensure protection of the internal components. Combined with beam level aiding the SPRINT-Nav will continue to function even if one of

the DVL transducers has been damaged.

SPRINT-Nav can be interfaced using a single connection and/or the internal sensors can be interfaced separately depending on requirements.

Internal battery backup provides continuous on-board navigation and data storage supporting post-mission diagnostics and post-processing, even throughout brownout periods.

It offers an easy-to-use Web UI, which provides an intuitive dashboard viewer as well as configuration and detailed status pages for integration and troubleshooting. A clearly defined API allows for deep integration into vehicle control systems and remote operation of the system.

Export of SPRINT-Nav is simple in comparison to other separate DVL and INS units. For example, shipping from outside the USA does not require a re-export licence.

Typical applications

- Any subsea vehicle including AUV and ROV
- Ideally suited for autonomous and resident vehicles
- Survey and construction

Key features

- World's highest performing hybrid navigator
- All-in-one turn-key solution
- Concurrent INS, DVL and ADCP output capability for multi-use
- Alignment in <5 minutes with DVL aiding
- Web user interface
- Proven long life and high MTBF inertial sensors from trusted long-term US supplier
- Remote diagnostics and performance verification
- Fully water blocked DVL endcap protecting internal electronics
- Full ocean depth aiding from USBL
- Two DVL frequencies available: 625 kHz or 375 kHz high altitude (HA)
- Export is not ITAR controlled

Specifications

SPRINT-Nav

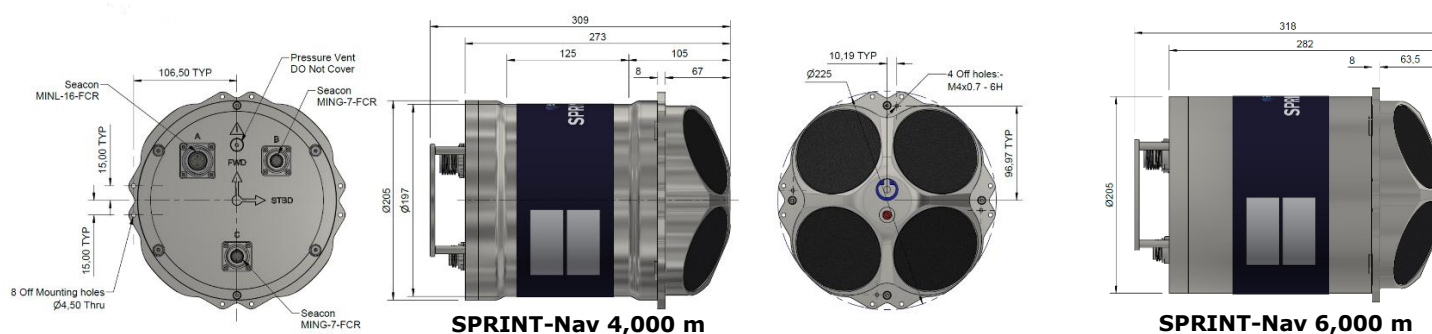

Performance		SPRINT-Nav I	SPRINT-Nav S	SPRINT-Nav X
DVL aided	Typical survey ¹	0.03%	0.02%	0.01%
	Distance from origin	0.10%	0.06%	0.04%
	High altitude (HA) option ²	0.12%	0.07%	0.05%
Unaided	Short term	1.2 m in 60 s	0.5 m in 60 s	0.3 m in 60s
	Long term	1 nm in 45 minutes	1 nm in 2.5 hours	1 nm in 8 hours
Altitude min/max	Standard	0.3/175 m		
	High altitude (HA) option ²	0.4/230 m		
USBL and DVL aided	Precision improvement	Up to 7x better	Up to 10x better	Up to 13x better
Station keeping		<2 m over 24 hours		
LBL/DVL aided		3 cm confined area, 20 cm wide area (dynamic)		
Heading (secant latitude) with GNSS or USBL and DVL		0.04°	0.025°	0.01°
Heading (secant latitude) with GNSS or USBL or DVL		0.05°	0.03°	0.01°
AHRS/INS roll and pitch ¹		0.01°	0.01°	0.01°
Heave ³		5 cm or 5%		
Pressure sensor ⁴		0.01% FS		
ADCP ⁵	Profiling range	625 kHz	0.4–80 m	
		375 kHz	0.4–120 m	
	Velocity range and RMS (along beam) ³	625 kHz	Up to ±5.6 m/s ±0.4% of measured value	
		375 kHz	Up to ±8.4 m/s ±0.4% of measured value	
Maximum number of cells		255		
Maximum ping rate		4 Hz (ADCP) or 10 Hz (DVL)		
Power				
Power requirements	DVL off	24 V dc ±10%, 18 W nominal, 30 W maximum		
	DVL on and battery fully charged	24 V dc ±10%, 25 W nominal, 30 W maximum		
Internal battery backup		Li-ion/5 minutes		
Physical/comms				
Data storage		64 GB internal memory		
Serial ports/protocol		2x RS232, 1x RS232 or RS485		
Other ports		Ethernet, 4 triggers		
Mechanical construction		Titanium		
Dimensions (diameter x height, including connectors)	4,000 m	205 x 309 mm		
	6,000 m	205 x 318 mm		
Weight air/water	4,000 m	20/11.1 kg		
	6,000 m	23/13.7 kg		
Environmental				
Depth rating		4,000/6,000 m		
Operating temperature		-5 to 50°C		
Storage temperature		-25 to 55°C		

¹ All accuracy figures related to time or distance are CEP50, all angular accuracies/heave are 1DRMS.

² High altitude DVL 375 kHz, standard is 625 kHz.

³ Whichever is greater, for wave periods up to 10 seconds.

⁴ 0.01% precision, 0.05% accuracy, relative to full scale of sensor, raw pressure available or processed depth by SPRINT-Nav.

⁵ Optional upgrade.