

Datasheet

SPRINT subsea INS



SPRINT is an Aided Inertial Navigation System (AINS) highly optimised for cost, size, weight and power (C-SWaP).

The instrument is a turn-key solution comprised of carefully selected high-grade and highly reliable inertial sensors integrated into a Sonardyne in-house designed Inertial Measurement Unit (IMU).

The selected inertial sensors are the standard for commercial aviation with a proven 20+ year track record. These sensors have the highly desirable characteristic of being insensitive to vibration, temperature changes and having very limited initial errors. The result is a system which is suitable for the marine environment where performance, robustness and data integrity need to be available from initialisation, even in the harshest conditions.

SPRINT's dual AHRS and INS algorithm capability is unique in the market and allows for automatic on-board integrity checking between algorithms as well as instantaneous INS start up with North alignment from the on-board AHRS. This capability allows for simultaneous use from one instrument, e.g. AHRS plus DVL for ROV piloting and INS plus DVL for survey operations.

Internal battery backup provides continuous on-board navigation and data storage supporting post-mission diagnostics and post-processing, even during brownout periods.

SPRINT interfaces with aiding sensors such as USBL, DVL, pressure sensor and sound speed.

Power-pass through to aiding sensors is supported to ease integration and enables SPRINT to be interfaced using a single connection.

SPRINT has a proven track record spanning over 10 years in diverse applications from ROV guidance and autopilot to demanding survey applications such as multibeam out-of-straightness surveys and sparse-LBL using tightly coupled 6G acoustics.

The instrument is available in 4,000 and 6,000 m depth ratings and is one of the smallest form factor subsea inertial instruments available.

Typical applications

- Vehicle guidance and control
- Station keeping and autopilot including mid-water applications
- USBL aided INS survey
- DVL aided relative navigation
- AUVs
- ROV and tow fish positioning
- Hydrographic survey
- Offshore construction
- As laid and out of straightness
- Multibeam survey
- Touchdown monitoring
- Structure placement

Key features

- Turn-key solution for motion sensor, gyrocompass and INS
- SPRINT provides concurrent AHRS and INS capability for dual use
- Fast follow up speed of 900°/sec
- Choice of depth ratings: 4,000/6,000 m
- Choice of connectors: Seacon (standard) or Seanet® (for use with FMC Schilling Robotics ROV)
- Transport approved rechargeable Li-ion battery back-up as standard
- 8 GB internal memory allows post processing and remote diagnostics
- Full ocean depth aiding from USBL
- Export is not ITAR controlled
- Ethernet and serial interfaces

Specifications

SPRINT subsea INS

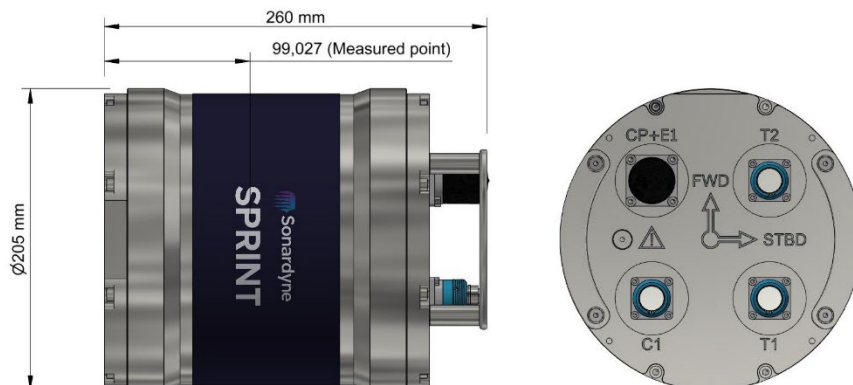

Performance		SPRINT 300	SPRINT 500	SPRINT 700
Heading		0.05° secant latitude	0.04° secant latitude	0.02° secant latitude
INS initialisation		Instantaneous		
Roll and pitch		0.01°		
INS aiding supported		USBL, depth, DVL, zero velocity, manual position, LBL, GNSS		
USBL/LBL aided		3x precision improvement	3.5x precision improvement	4.5x precision improvement
USBL/LBL and DVL aided		3 to 7 x precision improvement	4 to 10 x precision improvement	6 to 13 x precision improvement
LBL/DVL aided		3 cm confined area, 20 cm wide area (dynamic)		
DVL aided ^{1 2}	Typical survey	0.05%	0.03%	0.02%
	Distance from origin	0.15%	0.10%	0.08%
DVL aiding loss/drift ¹		1.2 m over 1 minute, 5 m over 2 minutes	0.8 m over 1 minute, 3.2 m over 2 minutes	<0.5 m over 1 minute, 2 m over 2 minutes
Station keeping		<1 m over 24 hours (Syrinx DVL)		
Power				
Power requirements		20–50 V dc, 15 W nominal (35 W maximum)		
Power pass through		3x for external aiding sensors (up to 3 A per sensor)		
Internal battery backup		Li-ion/5 minutes		
Data/Comms				
Data storage		8 GB internal memory		
Serial ports/protocol		4x RS232 or RS485		
Other ports		Ethernet, 4x triggers		
Output rate		Up to 100 Hz		
Mechanical				
Connectors options		4x Seacon/Seanet, 1x Seacon/Seanet		
Mechanical construction		Titanium		
Dimensions (diameter x height)	4,000 m (Seacon)	205 x 260 mm		
	6,000 m (Seacon)	205 x 280 mm		
	4,000 m (Seanet)	205 x 250 mm		
Weight in air/water ³	4,000 m	18.5/11.5 kg		
	6,000 m	22/14 kg		
Environmental				
Depth rating		4,000/6,000 m		
Operating temperature		-20 to +55°C		
Storage temperature		-20 to +60°C		
Shock rating		22 g, 11 ms half sine		

¹ CEP50 (assumes use of a high performance DVL such as the Sonardyne Syrinx 600).

² SPRINT-Nav performance achievable by co-locating with Syrinx DVL.

³ Estimated weights.