

Datasheet

Micro-Ranger Transceiver (MRT)



The Micro-Ranger Transceiver (MRT) Ultra-Short BaseLine (USBL) is an extremely small and light, Ethernet interfaced transceiver supporting Sonardyne's 6G[®] capable beacons.

This smaller USBL offers significant operational benefits due to its small size. The MRT is designed to run from Power over Ethernet (PoE), however it is also compatible with Sonardyne's Ethernet Serial Hub (ESH) which allows it to be used with the Micro-Ranger 2 system.

The multi-element processing enables transponders to be positioned up to 995 m in either shallow or deep water.

When used as part of a complete Micro-Ranger 2 USBL system, all the benefits of the feature rich software are available, such as output telegrams, positioning displays and diagnostic tools.

The integral AHRS sensor provides pitch, roll and heading data that automatically compensates for the dynamic motion of the vessel, removing the need for an external sensor and pre-use calibration.

The MRT is a highly capable acoustic transceiver allowing tracking of up to 10 targets using the Micro-Ranger 2 software. It's compatible with both the Wideband[®] Sub-Mini 6+ (WSM 6+) and the Nano Transponder beacons. Options to track autonomous underwater vehicles (AUVs) using the Nano AvTrak 6 OEM are also available.

The endcap is manufactured in stainless steel to allow it to be securely fitted and then removed from deployment poles repeatedly, whilst the body is made from a lighter weight ABS material. The MRT lends itself to over-the-side deployments on small vessels or even ribs.

The MRT has a volumetric array to allow tracking both below and above the transceiver; useful when tracking divers close to the vessel of opportunity.

Key features

- Easy to install and set up
- Supports WSM 6+ and Nano Transponder 6G beacons
- USBL design optimised for short range omni-directional performance
- The array design offers unrivalled range resolution and precision for a USBL system of this size
- Internal magnetic compass for instantaneous and calibration free motion compensation.
- Built in health checks including array and electronics diagnostics
- Ethernet connectivity using an ESH
- The Robotic Pack option enables Sonardyne's SMS acoustic messaging service and enables AUV tracking and control

Specifications

Micro-Ranger Transceiver (MRT)

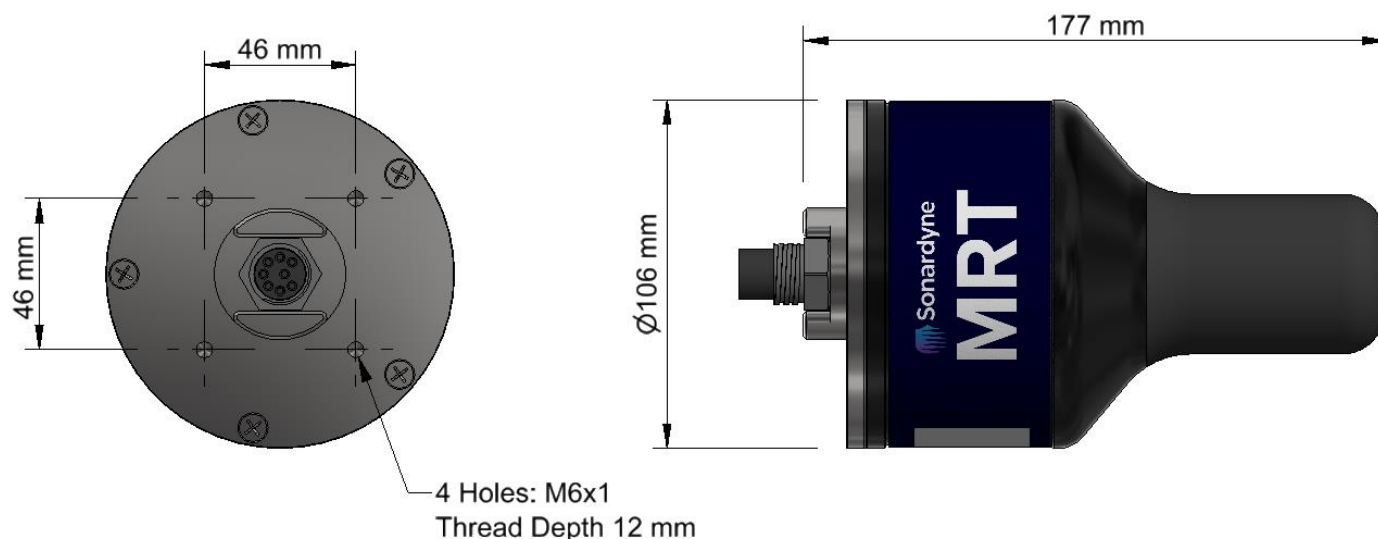

Feature	Type 8243
Operational frequency	MF (20–34 kHz)
Operating range	Up to 995 m
Depth rating	25 m
Acoustic coverage	Greater than 200°
Range accuracy ¹	Better than 15 mm
Angular accuracy ¹	±3°
Transmit source level (dB re 1 µPa @ 1 m)	184 dB
Electrical	48 V dc (±10%) typical 1.5 W, maximum 25.5 W
Communication	Ethernet 100 Mbps
Operating temperature	-5 to 40°C
Storage temperature	-20 to 55°C
Mechanical construction	Stainless steel 316, PVC and polyurethane
Dimensions (height x diameter)	177 x 106 mm (excluding connector)
Weight in air/water	1.84/0.99 kg

¹ The absolute accuracy of the system is dependent upon the quality of internal attitude and heading sensor which can be influenced by outside sources such as magnetic material, beacon source level, vessel noise, water depth, mechanical rigidity of the transceiver deployment, sound velocity knowledge and proper calibration of the system.