

Datasheet

Lodestar-Nav 200 - All-in-one Subsea Navigation



Lodestar-Nav 200 provides all-in-one navigation for subsea vehicles and survey operations by combining solid state Attitude Heading Reference System (AHRS), a Syrinx Doppler Velocity Log (DVL) and a high accuracy pressure sensor in a single housing. The Lodestar-Nav is upgradable to SPRINT-Nav Acoustically Aided Inertial Navigation System [AAINS].

The instrument is comprised of three high grade, high reliability, commercially available, Ring Laser Gyros (RLG) and accelerometers. The sensors are also the standard for commercial aviation with a proven 15+ year track record.

It is also fitted with a Syrinx DVL that provides a large altitude range and high precision at all altitudes; this combines the best of 300 and 1,200 kHz DVLs.

All onboard sensors are optimally integrated to provide seamless operation and unprecedented levels of performance compared with standalone instruments from different vendors.

The instrument requires no calibration for all but the most demanding applications with ultra-tight mechanical alignment.

The Lodestar 200 AHRS provides heading, pitch, roll accuracy and settle time that is class leading in the low-cost north seeking subsea AHRS category. It requires no external aiding and can settle in <15 minutes or less in dynamic conditions.

Syrinx DVL utilises both Doppler and Correlation technology to gain performance advantages in environments where each technology is best suited. Each DVL transducer is fitted with a full depth rated water block to ensure protection of the internal components.

Lodestar-Nav can be interfaced via a single connection and/or the DVL can be interfaced separately depending on requirements. Continuous on-board data storage supports post-mission diagnostics and post-processing.

Applications Include

- Ideally suited for Station-Keeping applications of ROVs and Hover Capable AUVs
- Manned submersibles
- Survey and construction

Key Features

- All-in-one subsea navigation
- Lodestar-Nav provides AHRS and DVL output capability for multi-use
- 0.4° (Lodestar) secant latitude heading accuracy
- 0.01° roll and pitch accuracy
- <10 minute AHRS settling time
- Small form factor – Easier mounting
- Proven long life inertial sensors from trusted long term US supplier
- Remote diagnostics and performance verification using on-board logging
- Lodestar-Nav AHRS can be remotely upgraded to SPRINT-Nav INS providing commercial and operational flexibility
- Class leading 600 kHz DVL combining the benefits of 300 and 1,200 kHz instruments in one
- Fully water blocked DVL endcap protecting internal electronics
- 0.01% full scale removable pressure sensor module
- 0.4–175 m DVL operating range
- Choice of depth ratings: 4,000 and 6,000 m

Specifications

Lodestar-Nav 200 - All-in-one Subsea Navigation

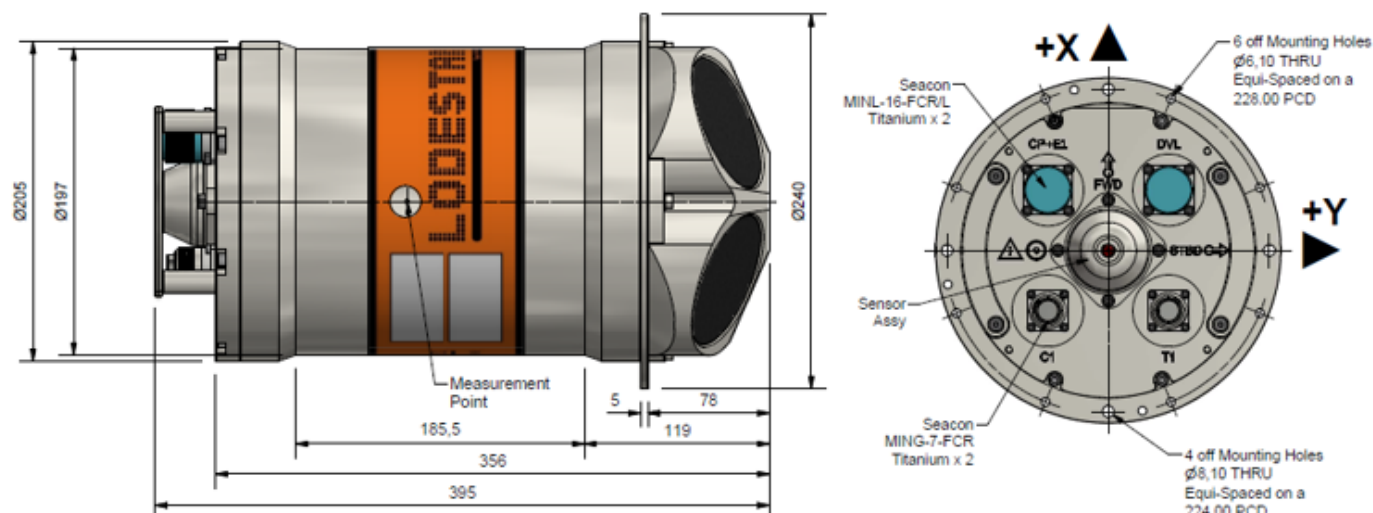

Feature		Lodestar-Nav 200 (4,000 m)	Lodestar-Nav 200 (6,000 m)
Depth Rating		4,000 m	6,000 m
Performance			
AHRS	Heading Accuracy (Secant Latitude)	0.4°	0.4°
	AHRS/INS Roll and Pitch Accuracy	0.01°	0.01°
	AHRS/INS Settle Time	<10 minutes in dynamic conditions	<10 minutes in dynamic conditions
DVL	Bottom Velocity	±0.22 cm/s	±0.22 cm/s
	Minimum/Maximum Altitude	0.4/175 m	0.4/175 m
	Long Term Accuracy	±0.12% ±0.1 cm/s	±0.12% ±0.1 cm/s
	Velocity Range	>10 m/s	>10 m/s
	Minimum/Maximum Altitude	0.4/175 m	0.4/175 m
	Velocity Resolution	0.01 cm/s	0.01 cm/s
Pressure Sensor		0.01% FS removable module	0.01% FS removable module
Power			
Power Requirement		20-50 V dc, 27 W nominal, 63 W maximum	
Power Pass Through		2 x for external aiding sensors (up to 3A per sensor)	
INS Battery Type/Life		Li-ion/5 minutes	Li-ion/5 minutes
Data/Comms			
Onboard Data Storage		AHRS 8 GB/ DVL 32 GB	AHRS 8 GB/ DVL 32 GB
Digital Ports/Protocol		Up to 4 digital ports/RS232 or RS485	Up to 4 digital ports/RS232 or RS485
Other Ports		2x Ethernet, 4 triggers	2x Ethernet, 4 triggers
Output Rate		Up to 100 Hz (AHRS), Up to 25 Hz (DVL), Up to 15 Hz (pressure)	
Output Telegrams		Industry standard AHRS/DVL/pressure telegrams including acceleration, rotation rates and temperature ¹	
Mechanicals			
Connectors		2 x Seacon (MING-7-FCR)/2 x Seacon (MINL-16-FCL/L)	
Mechanical Construction		Titanium	Titanium
Dimensions (Diameter x Height)		240 x 395 mm	240 x 405 mm
Weight in Air/Water ²		23.9/13.1 kg	28.1/17.2 kg
Environmental			
Operating Temperature		-5 to 50°C	-5 to 50°C
Storage Temperature		-25 to 55°C	-25 to 55°C
Shock Rating		22 g, 11 ms half sine	22 g, 11 ms half sine
Upgrades			
Lodestar-Nav 200 AHRS can be remotely upgraded to SPRINT-Nav 300 INS			

¹ Specific outputs may be limited below quoted performance for reasons of export classification and control and should not be used as IMU data.

² Estimated Weights.