

Datasheet

Stab and Receptacle



The Sonardyne Stab and Receptacle has been designed to allow precise installation of Sonardyne subsea positioning equipment on structures and other subsea equipment.

Its unique selling point is the high manufacturing tolerance combined with a pop-up tell-tale flag that provides visual confirmation the Stab is precisely docked in the Receptacle.

Using the Sonardyne Stab and Receptacle, the traditional method of rotating of a stab in a hub during metrology operations to determine stab-to-receptacle slop, can be eliminated. With this time consuming task removed, acoustic metrologies have the potential to be completed in less than 6 hours.

Additionally, the tolerance of the design allows for 0.1° for heading and 0.01° for pitch/roll which is the same quoted error of a calibrated Lodestar GyroCompatt. This improves the results of either the metrology or other positioning tasks and reduces the need for error determination of the stab/receptacle.

The Receptacle is designed to bolt into the eight bolt hole pattern of the industry standard 8" AWWA Class D flange. This allows the user to either bolt this flange onto the structure or to provide bolt holes in the structure itself. After dimensional control techniques to determine the relationship of the bolt holes in relation to the structure points of interest (jumper hubs, CRP, spool flanges, etc), the Receptacle can be bolted in with known offsets to these points. This allows fast and precise inferred metrology to one or multiple hubs or flanges from a single Receptacle.

The Receptacle features a 45° cone in which the Stab sits. This reduces the possibility of debris building up on the interface between the two and allows for a more precise connection due to the point of contact being exactly circular regardless of any small expansion /contraction effects.

The Stab also features an alignment bar rather than alignment pins to aid docking and provide superior heading alignment. An O-ring on the stab shaft assists in ensuring the two are precisely mated.

Key Features

- Designed to align repeatedly to 0.1° for heading and 0.01° for pitch/roll to add zero error if using a Lodestar GyroCompatt
- Tell-tale indicator confirms the stab is fully docked into the receptacle
- Exact fit and tell-tale indicator removes the requirement to rotate the Stab in the Receptacle saving time and potentially allowing acoustic metrologies to be completed in less than 6 hours.
- Receptacle is manufactured from high strength corrosion resistant plastic
- Receptacles eight bolt hole pattern designed on the industry standard AWWA Class D 8" flange
- Dimension control of the receptacle to structure hubs and flanges allows multiple metrologies to be completed simultaneously
- Two Stab variants available to bolt onto either Inclinator Compatts or GyroCompatts
- Stab is constructed from super duplex stainless steel - robust enough to allow it to be re-used.

Specifications

Stab and Receptacle

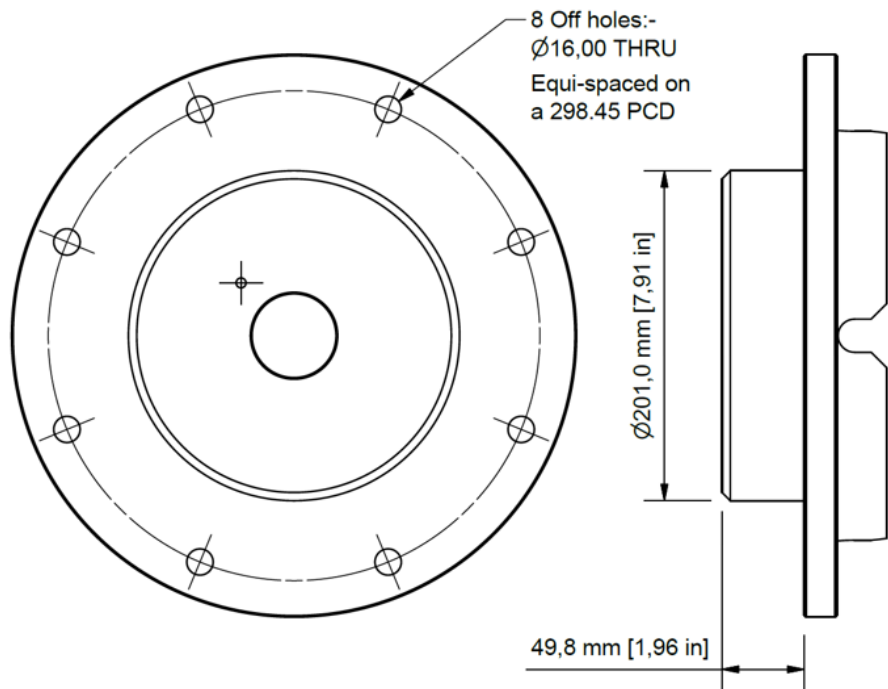
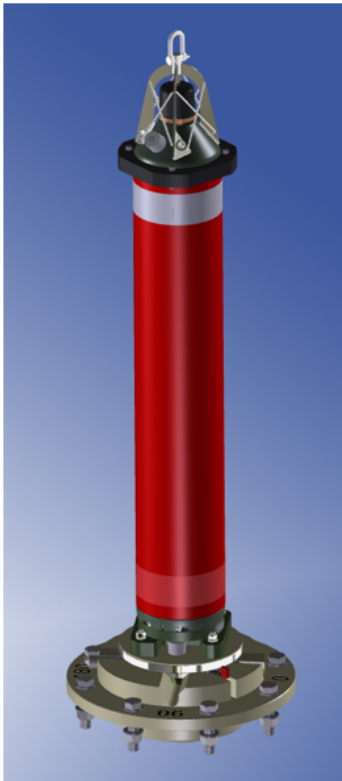

Feature	Receptacle Type 8300-250	Stab Type 8300-240	Stab Type 8144-150
Compatible Products	Stab 8300-240 & 8144-150	Inclinometer Compatt5 & 6	GyroCompatt6
Outside Diameter	343 mm	185 mm	185 mm
Maximum Height	100 mm	164 mm	164 mm
Stab face ¹ to Flange Face	76 mm	76 mm	76 mm
Mechanical Construction	Acetal (Delrin)	Super duplex stainless steel	
Bolt Hole PCD	298.45 mm	n/a	
Tell-tale	Removable	n/a	
Attitude Tolerance	Heading 0.1°, Pitch / Roll 0.01°		
Alignment Quadrants	Four (0°, 90°, 180°, 270°)		

¹ Includes stab isolation plate.