

**DEFENCE**  
**DETECT, PROTECT**  
**CLASSIFY, NAVIGATE**  
**TRACK, MONITOR**

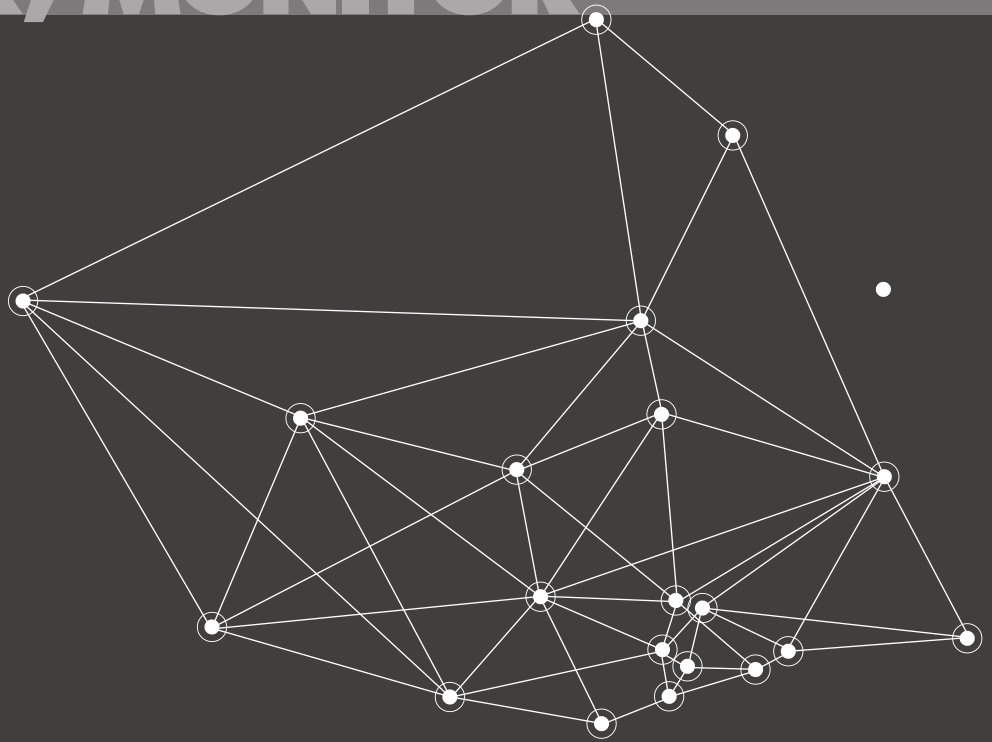

**POSITIONING**  
**NAVIGATION**  
**COMMUNICATION**  
**MONITORING**  
**IMAGING**

## OUR COMPANY

# WE MONITOR WE DETECT WE PROTECT WE TRACK

**ENSURE EACH AND EVERY MISSION IS A SUCCESS BY EQUIPPING YOUR SURFACE FLEET, MARINE AUTONOMOUS PLATFORMS AND COMBAT FORCES WITH OUR ACOUSTIC, SONAR, INERTIAL AND OPTICAL SUBSEA TECHNOLOGIES. WHY? BECAUSE THEY ENHANCE AND TRANSFORM YOUR OPERATIONAL CAPABILITY, CAN BE ADAPTED TO MEET ANY NEED AND COME WITH THE BACKING OF OUR GLOBAL SUPPORT NETWORK.**

### LOW RISK. HIGH RELIABILITY. FIT FOR PURPOSE

From our origins, operating in the North Sea in the early 1970s, innovation and performance have maintained our reputation for technical leadership. Today, we have an unrivalled portfolio of vessel-based and complementary sub-surface technologies that support your naval operations from homeland security to overseas campaigns in denied areas.

Marine autonomous systems are increasingly being entrusted to conduct a multitude of tasks. Whether it's a swarm of autonomous vehicles mapping areas for mine-like objects or a glider gathering tactical oceanographic data, we provide the equipment so that you can track, command and control your assets, reduce risk to personnel, improve your decision making and deliver the operational endurance you need.

### EVERYTHING UNDER ONE ROOF

We are a vertically integrated company with research, production, testing, compliance, distribution and support all under one roof.

In many cases, vessels, underwater platforms and operating environments are unique. So, when standard off-the-shelf equipment is not suitable, we have the know-how and in-house resources to adapt, test and manufacture highly reliable, fit-for-purpose customised solutions, on time and on budget. Then, we're there around the clock to install, train and maintain.



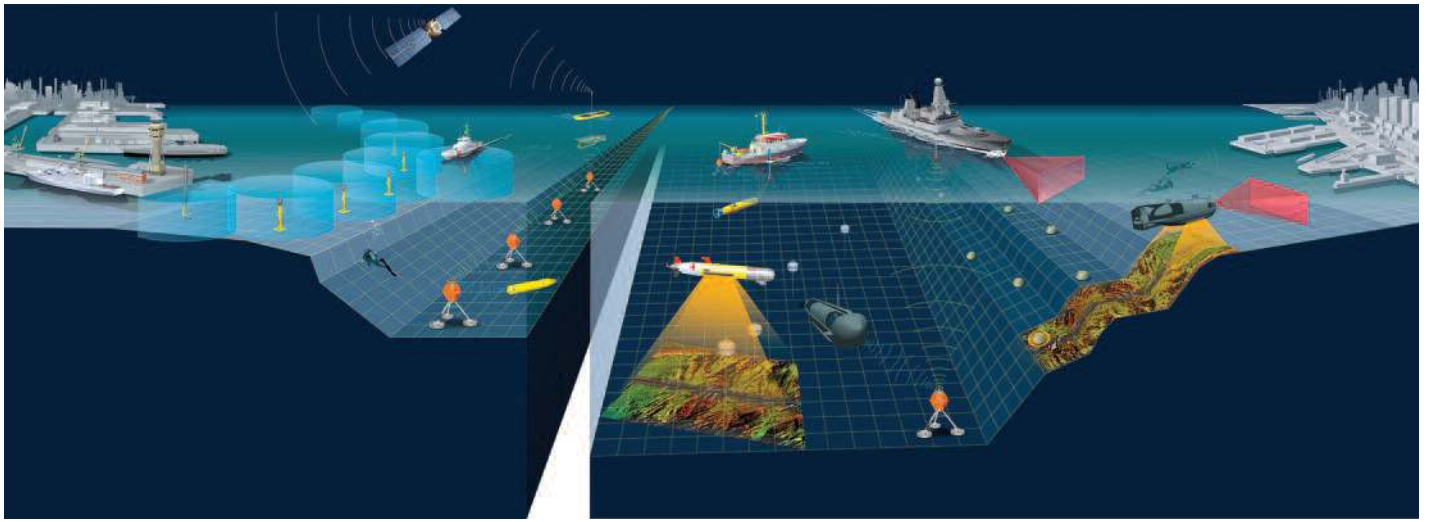

## PORT AND VESSEL PROTECTION

# SENTINEL INTRUDER DETECTION SONAR

**NAVAL SHIPS ANCHORED OFF THE COAST OR BERTHED IN PORTS ARE DIFFICULT ASSETS TO PROTECT BECAUSE OF THEIR SIZE AND PROXIMITY TO COMMERCIAL SHIPPING TRAFFIC AND LEISURE CRAFT USERS. WHILE MEASURES SUCH AS FLOATING BARRIERS OFFER PROTECTION AGAINST SURFACE ATTACK USING FAST BOATS – DIVERS AND UNDERWATER DRONES POSE A GROWING, YET CHALLENGING THREAT TO DETECT. YOU CAN CLOSE THE GAP IN YOUR SITUATIONAL AWARENESS BY SPECIFYING SENTINEL, THE WORLD'S MOST WIDELY DEPLOYED UNDERWATER INTRUDER DETECTION SONAR.**

### TIME IS OF THE ESSENCE

Sentinel is Commercial Off-The-Shelf (COTS) underwater security technology that detects, tracks and classifies divers and Unmanned and Autonomous Underwater Vehicles (UUV/AUVs) approaching a protected asset from any direction and alerts security personnel to the threat. In service around the world, Sentinel delivers a rapidly deployable force protection capability with reliable threat detection, solid tracking performance, very low false alarm rates and long-range performance – even in challenging environments like ports.

The small and lightweight sonar head is quick to deploy from a boat, install in a port or fix along a coastline – providing you with an instant underwater security shield. We've engineered all of the complexity associated with configuring and operating advanced sonar technology into easy-to-use software meaning that your personnel don't need to be sonar experts to use it. In fact, once it's set up, Sentinel can be left to run autonomously.

### RAPID DEPLOYMENT

The ability to reliably detect underwater intruders and AUVs in real-time at long range is essential to providing time for ship security officers to react to a security breach. Vital minutes can make the difference between successful threat interception and divers or underwater vehicles being able to deliver their attack.

Sentinel's compact size and lightweight design make it a practical solution for protecting military ships visiting overseas ports, as well as homeland roles, securing naval bases and ports of embarkation/debarkation. With both temporary and permanent installation options, Sentinel can be deployed over-the-side of small craft patrolling inland waterways, through the hull of a naval vessel (e.g. Offshore Patrol Vessels) or lowered on a lightweight frame directly onto the seabed.

If required, track data can also be exported via an open, industry standard interface to the vessel's Combat Management System or integrated bridge.

### WHY CHOOSE SENTINEL FOR PROTECTING YOUR ASSETS

- Delivers wide-area surveillance of the underwater domain
- Expeditionary or permanently installed equipment configurations
- Small, lightweight sonar head; man-portable
- Classifies threats as scuba, closed circuit diver or Swimmer Delivery Vehicle
- Optional underwater loudhailer to warn away intruders
- Long-range performance



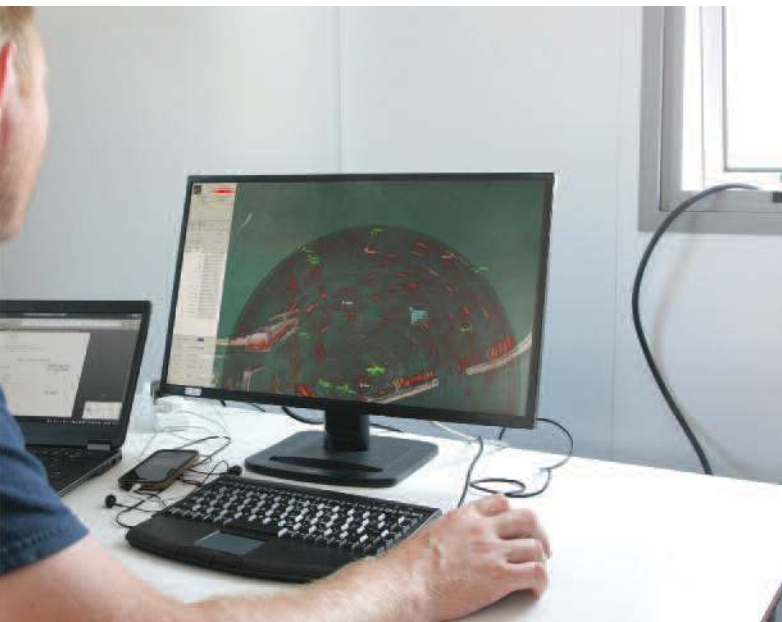

## PLATFORM NAVIGATION

# LODESTAR AHRS SYRINX DVL SPRINT INS

**FIT OUR LODESTAR ATTITUDE HEADING REFERENCE SYSTEM (AHRS), SYRINX DOPPLER VELOCITY LOG (DVL) OR SPRINT INERTIAL NAVIGATION SYSTEM (INS) TECHNOLOGIES TO YOUR SURFACE AND SUBSURFACE PLATFORMS AND BENEFIT FROM CONTINUOUS, HIGH-GRADE NAVIGATION. ALL SOLUTIONS OFFER LOW MAINTENANCE, HIGH MEAN-TIME BETWEEN FAILURES AND SIMPLE OWNERSHIP LOGISTICS, THANKS TO THEIR CALIBRATION-FREE DESIGN AND UK MANUFACTURE.**

### LODESTAR AHRS

Lodestar is a north-seeking gyrocompass and AHRS that replaces the need for a separate motion reference unit and gyrocompass onboard a ship. Under the water, its high update rate heading, pitch and roll output ensures that Swimmer Delivery Vehicle (SDV) pilots are able to follow a route to their target destination.

Lodestar uses the same Honeywell ring laser gyros (RLGs) and accelerometers fitted to most commercial airliners and space exploration platforms, so you can be assured of class-leading levels of performance and reliability.

### SYRINX DVL

A DVL measures the velocity of an unmanned underwater vehicle as it travels over the seabed and is considered an essential component of any navigation solution. Our Syrinx DVL is designed to meet the mission needs of vehicles that are required to operate at a range of altitudes, water depths and seabed types. With depth rating options down to 6,000 metres, Syrinx is ready to deliver continuous and accurate navigation data for the deepest of missions.

Syrinx can also be hull-mounted in a surface vessel to support slow speed manoeuvring (e.g. docking) when other navigation sensors become less effective or in GNSS-denied areas.

### SPRINT INS

SPRINT improves the speed and efficiency of ROV, AUV and SDV guidance with high quality inertial measurements aided by your vehicle's DVL, pressure sensor and acoustic tracking system.

Available in multiple performance levels to support simple to complex operational scenarios, SPRINT shares the same hardware platform as Lodestar, enabling you to upgrade capability in the field. An electronics-only option provides the flexibility to repackage the INS with your other payload sensors.

SPRINT is also available integrated with Syrinx. Called SPRINT-Nav, it's one of the smallest inertial-DVL navigation instruments available. Mechanical alignment of the sensors improves accuracy and ensures a rapid and simple mobilisation. And, thanks to the tight beam-level aiding from SPRINT, navigation is possible even if one or two DVL beams are unavailable.

### WHY CHOOSE LODESTAR, SPRINT AND SYRINX FOR NAVIGATION

- Delivers unprecedented levels of navigation for ROVs and AUVs
- AHRS, INS and DVL all from one manufacturer
- Lodestar and SPRINT built around high-grade Honeywell RLGs
- Syrinx is UK-made for easy export
- Integration service available to equip your vehicles with our technology

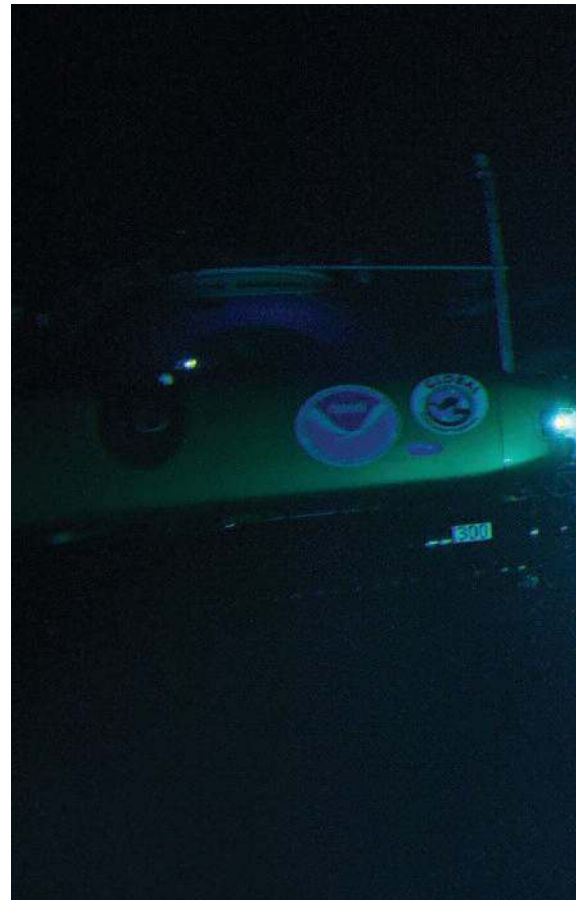

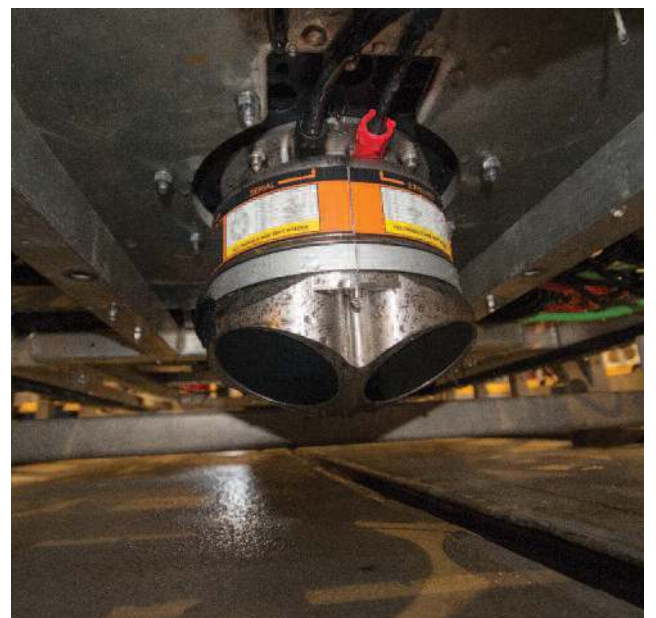
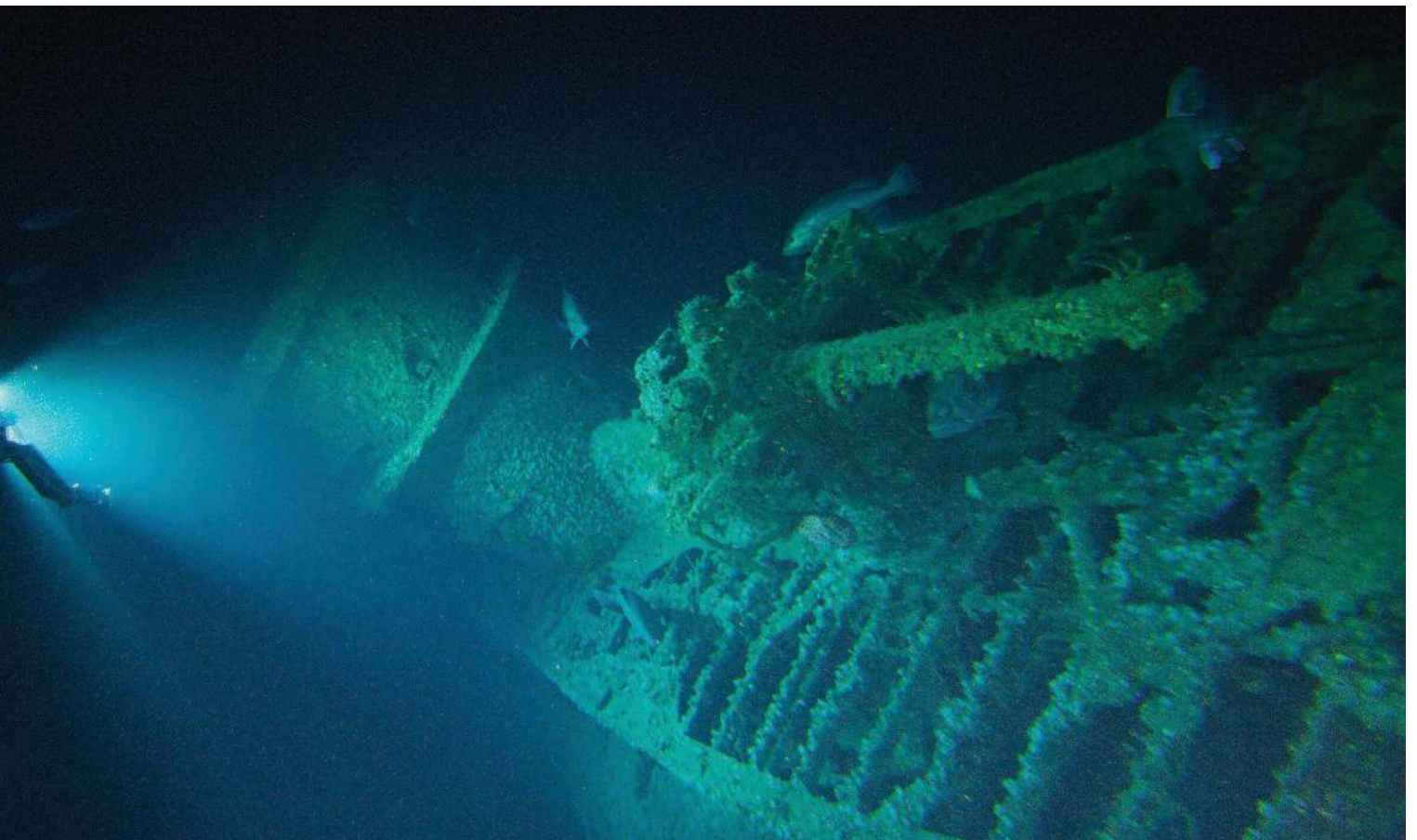

## TARGET TRACKING

# MICRO, MINI AND RANGER 2 TRANSPONDERS AVTRAK 6

**YOUR MISSIONS CAN BE CONDUCTED USING A COMBINATION OF DIVERS, TOWED AND SEAFLOOR SENSORS, AND MANNED AND UNMANNED UNDERWATER VEHICLES. OUR WIRELESS TECHNOLOGY PROVIDES YOU WITH THE CAPABILITY TO TRACK THEIR EVERY MOVE, COMMUNICATE WITH THEM AND EVEN RECEIVE DATA BACK FROM THEM. THE HARDWARE YOU'LL NEED IS QUICK TO MOBILISE ON TO PLATFORMS AND, THANKS TO OUR SECURE WIDEBAND SIGNAL PROTOCOLS, IT WILL WORK RELIABLY IN ALL OPERATING ENVIRONMENTS – DEEP OR SHALLOW.**

### MICRO-RANGER 2, MINI-RANGER 2 AND RANGER 2

No matter if your off-board assets operate just off the coast or far from shore, our Micro-Ranger 2, Mini-Ranger 2 and Ranger 2 USBL systems provide you with the capability to know exactly where they are relative to your vessel's (manned or unmanned) position. Transit to a location, fit a transponder, deploy it and track it; our USBLs are fast, precise and efficient, meaning that your mission will be also.

Micro-Ranger 2 is extremely portable and has a tracking range of 995 metres. Mini-Ranger 2 can track to 4,000 metres and is ideal for permanent installation on offshore patrol vessels. For large ships, Ranger 2 can track ROVs, UUV/AUVs, manned submersibles and towed platforms to beyond 11,000 metres and has the added capability of providing position reference data for your ship's Dynamic Positioning (DP) system.

### TRANSPONDERS TO FIT YOUR MISSION

Payload is a crucial consideration for any operation, so it's important to select the right USBL transponder. We supply an extensive range including: Nano, our smallest ever 6G-enabled (sixth generation) transponder measuring just 155 millimetres long and weighing in at 200 grams in water; WMT, a high-power transponder with depth options to 7,000 metres; and RT 6, a transponder that helps you covertly deploy, track and recover seabed equipment.

### ALL-IN-ONE FUNCTIONALITY WITH AVTRAK 6

If you want to communicate with, as well as track your asset, AvTrak 6 is one of the most capable instruments you can fit to your underwater vehicle. It combines transponder, transceiver and telemetry link functionality in one low power unit that has been designed to allow interaction with AUVs while the vehicles are underway. Available in three different form factors to suit large and small platforms, including man-portable vehicles, AvTrak 6 enables AUV-to-AUV communications for swarm deployments.

Divers can also benefit from a variant specifically developed for integration with tactical swim boards and SDVs. Messages can be broadcast to all the divers in range enabling a quick reaction, if required. Divers can also send status information and urgent pre-defined messages to the surface and other divers.







## WHY CHOOSE RANGER 2 AND AVTRAK 6 TO POSITION YOUR TARGETS

- Capable of tracking multiple underwater targets to beyond 11,000 metres
- Portable and quick to mobilise on all vessel types, including unmanned underwater platforms
- Simple and intuitive software; quick for personnel to learn
- Integrated, high security two-way control and telemetry data link
- Can be used to relocate aircraft flight recorders lost in water



Transducer and PCB shown actual size (56 millimetres x 88 millimetres)



## SITUATIONAL AWARENESS

# NAVIGATION AND OBSTACLE AVOIDANCE SONAR-NOAS

**RADAR AND AIS ALERTS YOU TO NAVIGATION HAZARDS ABOVE THE WATER, BUT WHAT ABOUT THOSE BELOW IT? POORLY CHARTED WATERS AND SUBMERGED OBJECTS CAN CAUSE YOUR VESSEL TO RUN AGROUND OR HAVE A COLLISION, PLACING CREW AND NAVAL ASSETS AT RISK. INSTALL OUR NAVIGATION AND OBSTACLE AVOIDANCE SONAR AND TRANSFORM YOUR UNDERWATER SITUATIONAL AWARENESS.**

### SEE WHAT LIES AHEAD

Piloting and charting errors are the largest causes of vessel groundings and collisions. That's why, if your ship is transiting, even along familiar routes, a forward-look sonar will help you see what lies ahead under the water and automatically warn you of hidden dangers.

Using dual sonar transducers installed in the bow, NOAS works by scanning the water column at a navigational significant range ahead of the vessel to generate a 3D model of the seabed. The model is displayed relative to the vessel and overlaid on nautical charts in real-time, providing officers of the watch with an easy to interpret image of the underwater topography the vessel is passing over.

Alerts can be configured to warn helmsmen of potential collisions with unseen hazards or shallow water. These can be based on depth, distance from the vessel and estimated time to impact. Multiple alerts can be programmed and are displayed in the profile view and depth scale. Uniquely, NOAS can also be utilised with our Sentinel sonar to offer an intruder detection capability to warn of divers approaching your ship when it's stationary.

### NEW BUILD OR RETROFIT

NOAS is suitable for both new build and retro-fit installations on many vessel types, including minehunters, hydrographic survey ships, offshore patrol boats and autonomous ships.

### SWIMMER DELIVERY VEHICLES

Applications for NOAS extend beyond surface vessels to guiding large Swimmer Delivery Vehicles that are in service with multiple navies around the world. The onboard display enables pilots to remain submerged and concealed throughout the insertion and extraction phases of their mission.

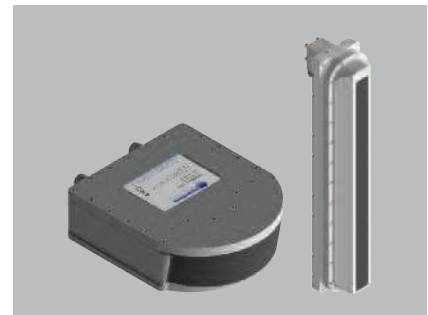
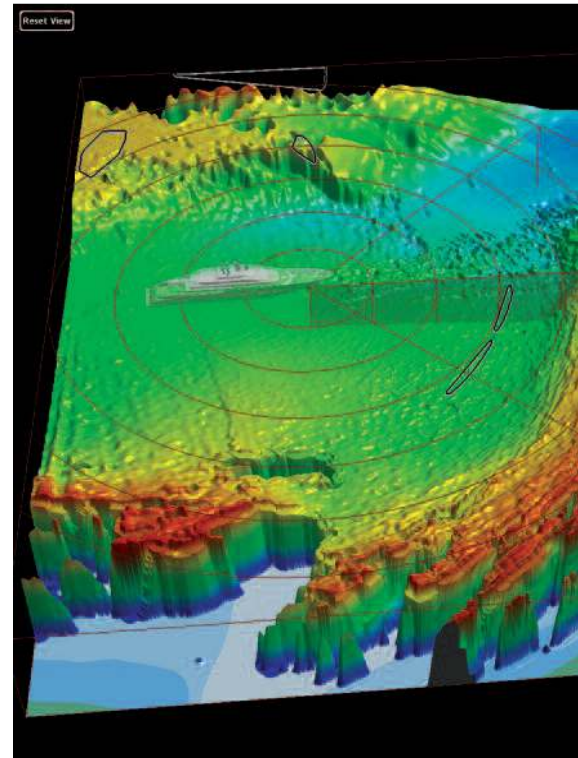

### WHY CHOOSE NOAS TO GUIDE YOUR PASSAGE

- Provides long-range detection of seafloor and floating navigation hazards
- Retains history of vessel passage to assist with manoeuvring
- Configurable users displays and alarms, including estimated time to impact
- Designed for new-build, retro-fit vessels and SDVs
- Optional diver detection security mode to warn of threats when anchored



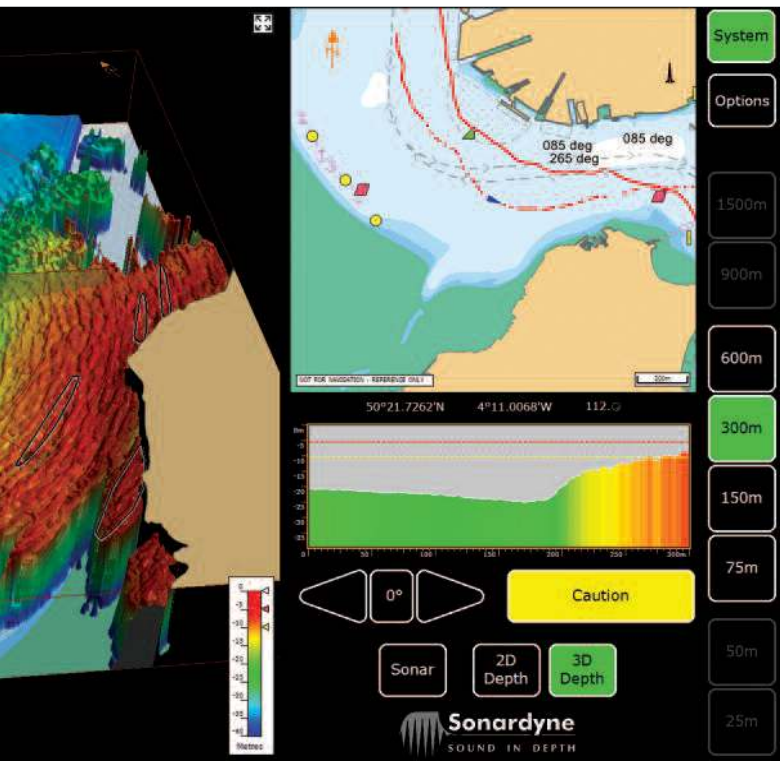

## INTELLIGENCE, SURVEY AND RECONNAISSANCE

# FETCH AND ACOUSTIC TELEMETRY

**GATHERING, PROCESSING AND DELIVERING INTELLIGENCE DATA ABOUT WHAT IS HAPPENING IN THE MARINE ENVIRONMENT, IMPROVES YOUR SITUATIONAL AWARENESS AND OPERATIONAL DECISION MAKING. OUR ACOUSTIC MONITORING TECHNOLOGIES SUPPORT INTELLIGENCE, SURVEY AND RECONNAISSANCE (ISR) MISSIONS WITH INSTRUMENTS BUILT TO BE DEPLOYED FOR 10 YEARS OR MORE AND CONFIGURED TO RUN AUTONOMOUSLY AND BE ACCESSED REMOTELY VIA SURFACE OR SUBSURFACE PLATFORMS.**

### MONITOR WITH FETCH

Fetch is a self-powered, leave-behind sensor logging node that enables environmental and surveillance data to be collected, stored and offloaded on demand, via a secure digital acoustic communications link.

Fetch units can be deployed in a number of ways, including in tripod frames and free fall dropped into the water from a surface vessel, touching down on the seabed in an upright position ready to begin monitoring. This simple yet effective deployment technique allows a wide-area monitoring network to be quickly and efficiently established and remain active in excess of 10 years.

Depth rated to 3,000 metres, Fetch can be configured with different sensors to meet your monitoring needs, including high-accuracy pressure, temperature and sound velocity data, as well as inclination. Other third-party situational awareness sensors can be integrated internally or externally as required.

### OVER-THE-HORIZON CONOPS

An integrated modem supporting transfer rates of up to 9,000 bps enables data gathered by Fetch to be reliably transferred up to a surface ship. Alternatively, we can supply topside systems that facilitate over-the-horizon concepts of operations (CONOPS), which eliminate the need to send a manned vessel into a theatre of operation.

Our low-power acoustic communications module can be fitted to a gateway buoy or in the hull of Unmanned Surface Vessels (USVs) from leading vendors. These are able to covertly loiter for long periods and, when required, navigate to a precise location to begin transferring data from the seabed to analysts located anywhere in the world. The two-way link enables mission updates to be sent down to Fetch and, when required, Fetch can be acoustically commanded to release from its stand and return to the surface under its own buoyancy, ready for collection.

Image: C. David Chadwell / WHOI ROV Jason

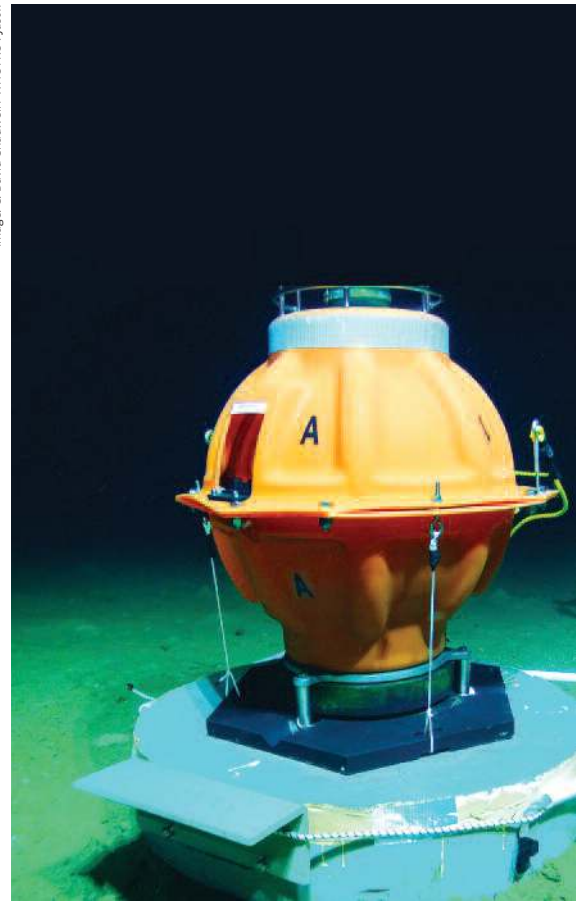

### WHY CHOOSE SONARDYNE MONITORING TECHNOLOGY

- Wide variety of sensor options to suit any covert surveillance application
- Rapidly deployable from a moving surface vessel
- Can remain continuously deployed and monitoring for more than a decade
- On-demand data harvesting from vessel of opportunity, gateway buoy or persistent unmanned vehicle
- Low-risk and proven track record



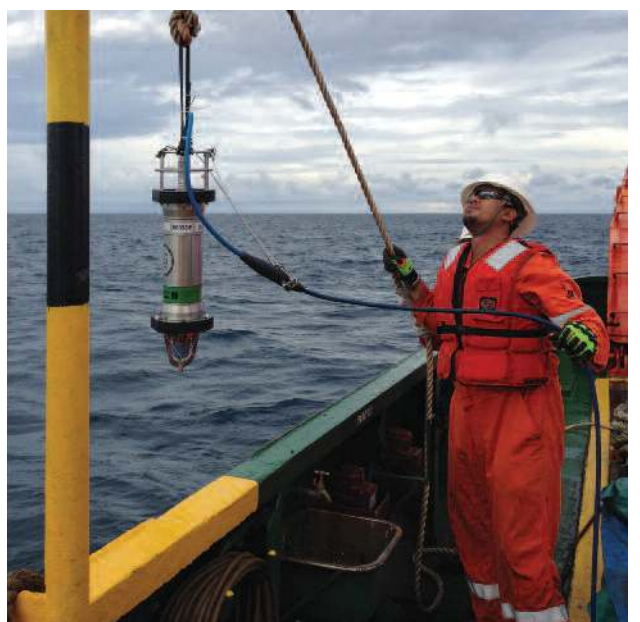

## MCM AND HYDROGRAPHY

# SOLSTICE MULTI APERTURE SONAR

**TODAY, OFF-BOARD ASSETS SUCH AS UNMANNED UNDERWATER VEHICLES ARE COMMONLY FOUND WORKING ALONGSIDE MINE COUNTER MEASURE (MCM) VESSELS TO CONDUCT ROUTE SURVEYS, SEABED CLEARANCE AND ORDNANCE CLEARANCE OPERATIONS. THE GOALS, HOWEVER, REMAIN THE SAME: REDUCE THE SENSOR-TO-SHOOTER TIMELINE, IMPROVE PERCENTAGE CLEARANCES AND MINIMISE RISK TO PERSONNEL AND THEIR EQUIPMENT.**

### SOLSTICE MULTI APERTURE SONAR

We support mine hunting and clearance missions with Solstice, our Multi Aperture Sonar (MAS). Designed for installation on low logistic AUVs, the imagery gathered by Solstice is independently considered the highest quality possible from a side scan sonar. This enables operators to make classification decisions with greater levels of confidence in less time.

Solstice uses the input from 32 elements to dynamically focus along the whole length of the 200 metre swath. The process generates narrow 0.15° along-track beams consuming just 18 watts, placing very little drain on a vehicle's power budget. Solstice's bathymetric data is co-registered onto the same pixel grid as the side scan imagery, and therefore can produce stunning digital terrain maps. It is ideally suited for MCM and hydrography.

Unlike conventional side scan sonars, Solstice provides higher precision actionable data across the whole swath, improving detections and reducing false alarms, and is suitable for on-board 'in-stride' Computer Aided Detection and Classification (CAD/CAC) and Automatic Target Recognition (ATR). The output data files are compatible with leading Post-Mission Analysis (PMA) software packages.

### SIMPLE INTERFACES

Solstice has a track record with leading AUV brands and integration into new platforms is straightforward. Every Solstice is provided with a simple Interface Control Document (ICD) to simplify the integration into low-logistic AUVs.

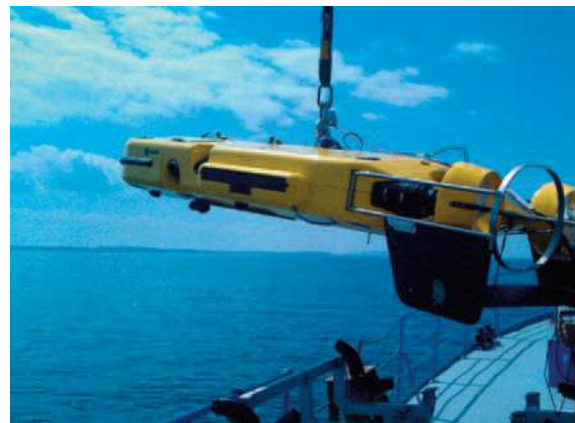

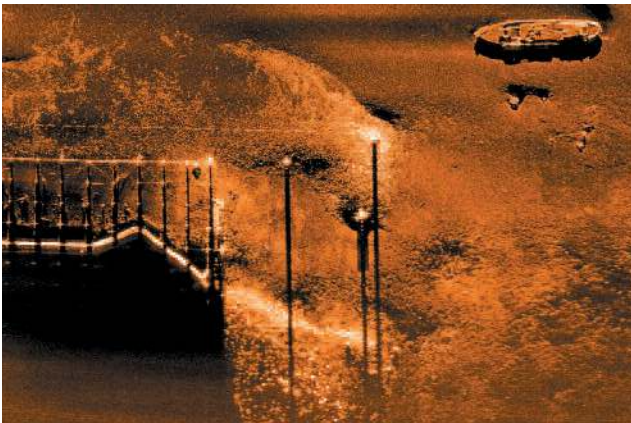
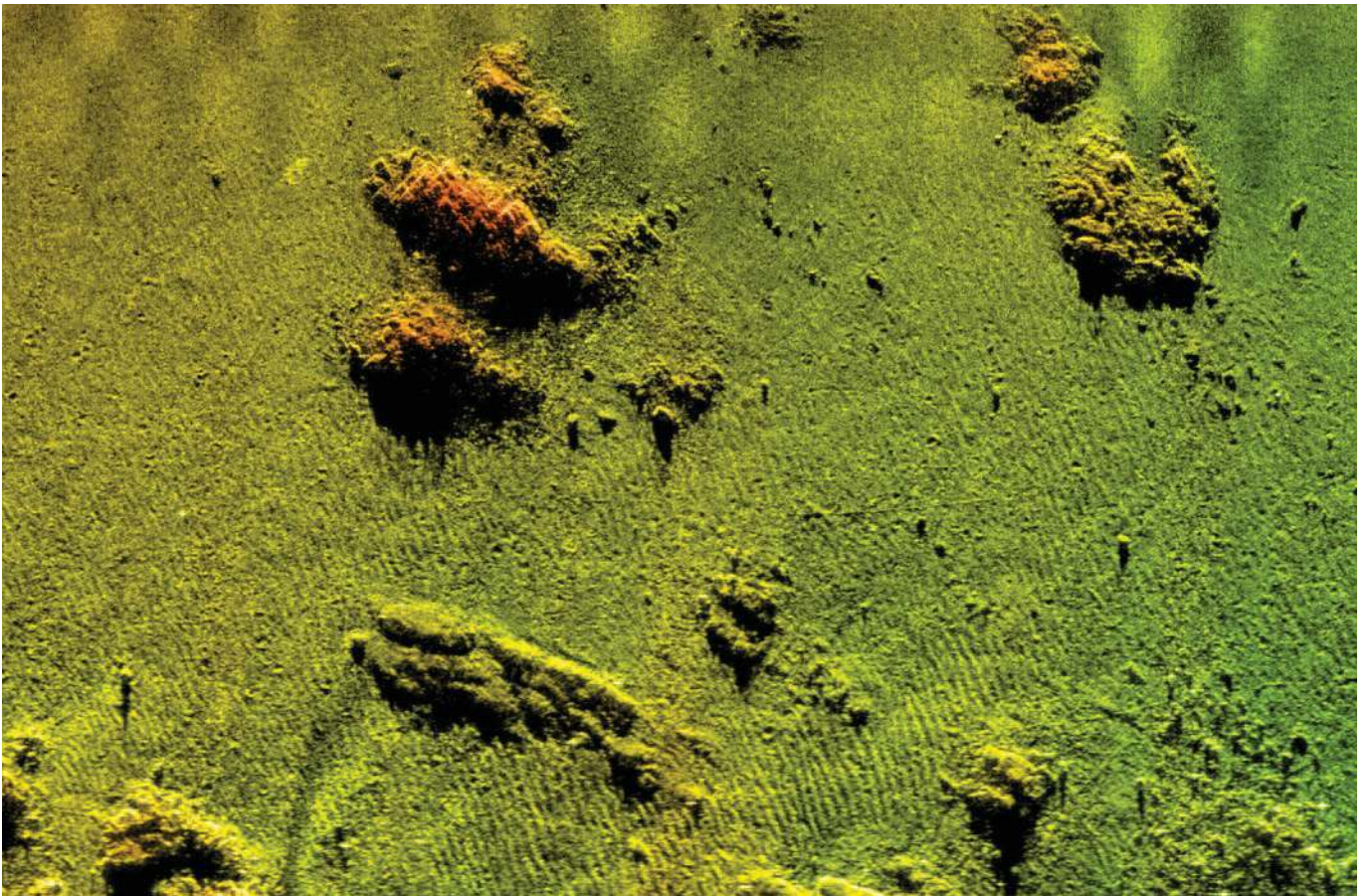

### **WHY INVEST IN SONARDYNE IMAGING TECHNOLOGY**

- Suitable for low-logistic AUVs
- Solstice images are designed to be of the highest quality possible from side scan sonar
- Wide swath coverage ensures high coverage rate
- Low power consumption increases the operational envelope of your vehicle
- Option to geocode all data on-board optimising Post-Mission Analysis process
- In service with leading vehicles AUV manufacturers
- Fully supported vehicle integration service

## SENSOR DEPLOYMENT AND COMMUNICATIONS

# RT 6 MODEM 6 BLUECOMM

**OUR ACOUSTIC AND OPTICAL COMMUNICATION INSTRUMENTS ARE TRANSFORMING THE WAY TACTICAL SUBSEA DATA IS COLLECTED AND DISSEMINATED. IT'S NOW POSSIBLE TO DEPLOY IN-SITU SURVEILLANCE SENSORS FOR MONTHS, IF NOT YEARS AT A TIME, AND WIRELESSLY CONNECT THEM TO MILITARY COMMANDERS AND NATIONAL SECURITY**

### MODEM 6

Modem 6 instruments use our Wideband 2 spread-spectrum digital signal processing to provide reliable, bi-directional communications with data rates up to 9,000 bps. The technology is mature and low-risk with a track record of operations from many different platforms, including long-endurance USVs, which have demonstrated routine data harvesting from a network of monitoring nodes in depths in excess of 5,000 metres.

### BLUECOMM FOR LARGE DATA VOLUMES

Increasingly, acoustic telemetry systems just aren't fast enough to transmit the large amounts of data being collected by bottom-mounted surveillance arrays. Until recently, the only option has been to recover each instrument to the surface, which is inconvenient, highly visible and time-consuming. Our high-speed optical modem, BlueComm, changes everything.

Using rapidly modulating LEDs, a pair of BlueComm modems can transfer large volumes of data at high speed (from five to 500 Mbps) over hundreds of metres to one another – and do it all consuming very little power, making it ideal for low-powered unmanned or autonomous platforms. Fitted with BlueComm, an AUV or submarine can pass through an area containing deployed data-logging instruments and covertly harvest the logged data.

### RELEASE TRANSPONDER 6 (RT 6)

When deploying seabed hardware that needs to be subsequently recovered, RT 6 (Release Transponder 6) is the perfect instrument. It's an acoustic positioning transponder with integrated release mechanism that can be used to trigger a range of events on command from the surface. Most commonly, this is the release of a drop weight so that attached hardware can float back to the surface, all while being tracked with your Sonardyne Ranger 2 USBL system.





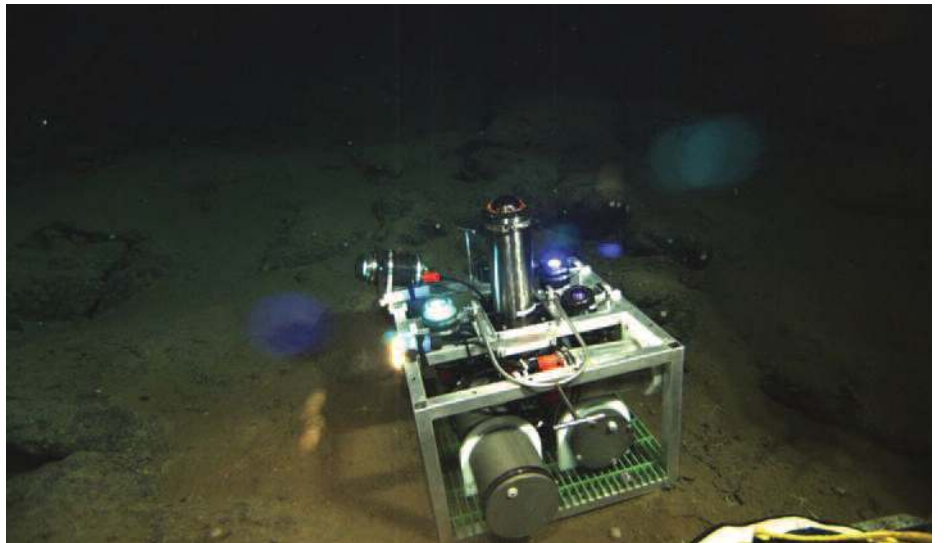
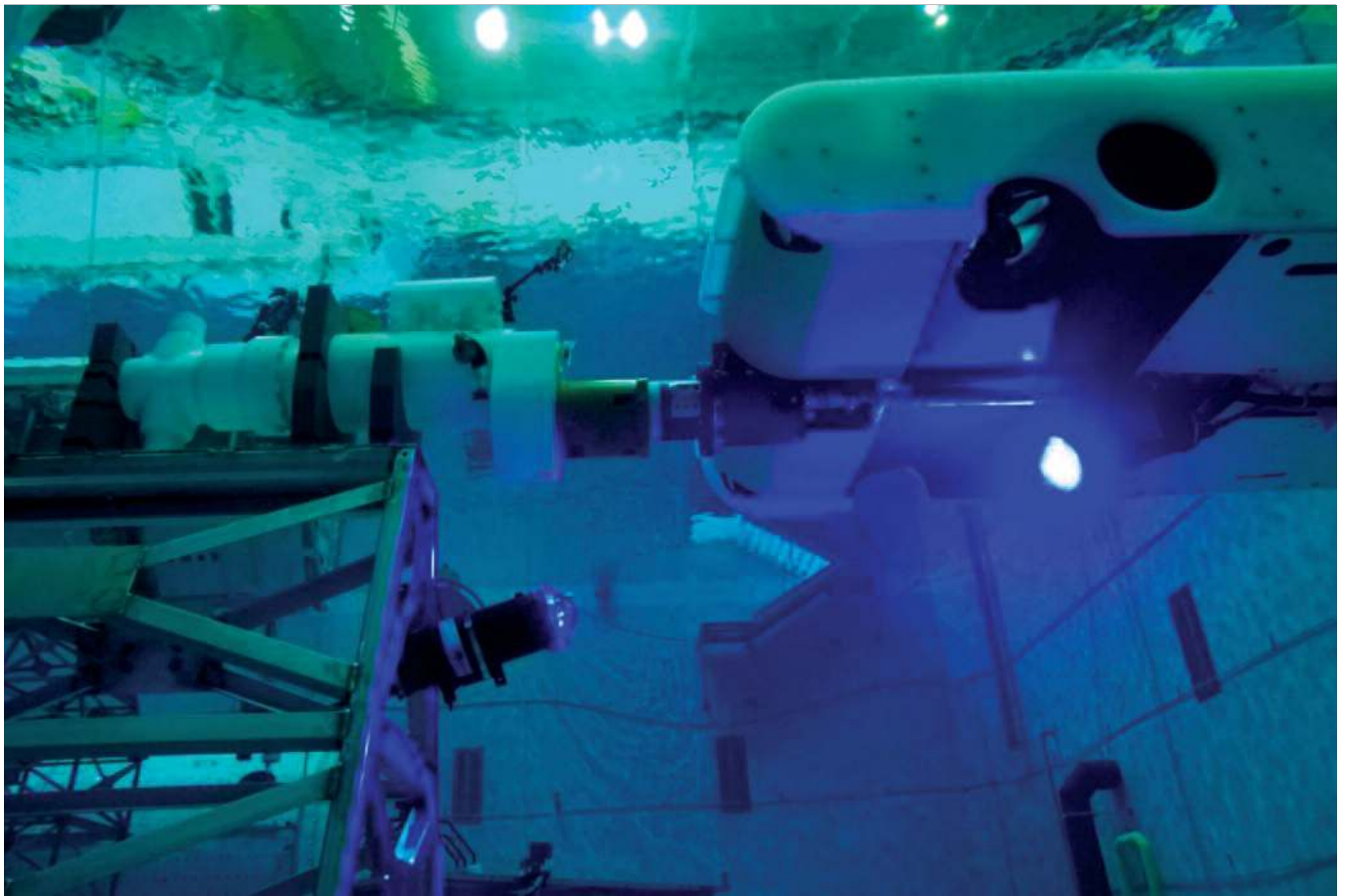

### WHY CHOOSE SONARDYNE TO DEPLOY SENSORS AND RECOVER DATA

- Highly reliable release transponders with long endurance capability and compatibility with Ranger 2 USBL
- Depth ratings to 6,000 metres
- Secure and robust acoustic modem; up to 9,000 bps
- BlueComm provides high bandwidth telemetry capability for rapid, large data transfer
- BlueComm enables live video streaming, tetherless vehicle control and data harvesting

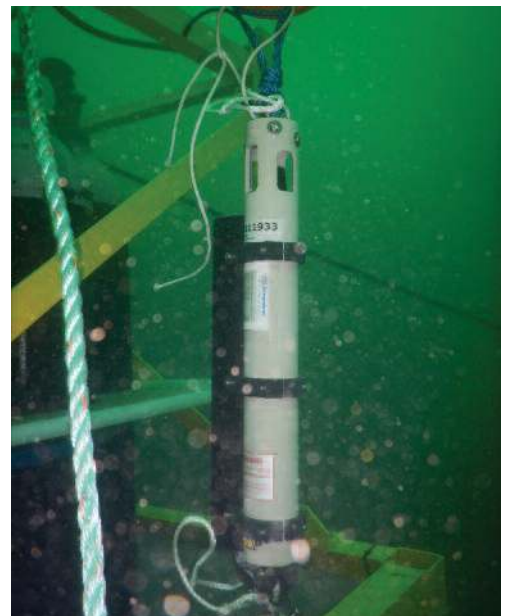

## DEFENCE CAPABILITIES

# AT A GLANCE

### PORT AND VESSEL PROTECTION > SENTINEL

Close the gap in your situational awareness by specifying the world's most effective underwater intruder detection sonar, Sentinel, to help safeguard your maritime assets: domestic naval bases, vessels at anchor, visiting foreign ports.



- Provides reliable detection, tracking and classification of intruders
- Detects divers at up to 900 metres range; underwater drones at up to 1,200 metres
- Scalable coverage to protect very large naval bases
- Wide range of deployment options: over-the-side, permanent, portable

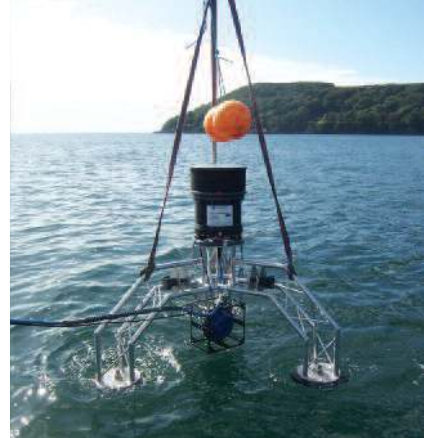

### PLATFORM NAVIGATION > LODESTAR AHRS / SPRINT INS

With a track record spanning 10 years in high-grade surface vessel and subsea vehicle guidance, our Lodestar AHRS and SPRINT INS range has now evolved into its third generation to meet the needs of any naval application.



- Fitted with Honeywell ring laser gyros inside
- Depth ratings down to 6,000 metres
- Multiple performance levels; field upgradeable
- Fast settling time so you can get straight to work
- OEM options available



### PLATFORM NAVIGATION > SYRINX DVL

Syrinx is a 600 kHz DVL for surface and subsea vehicles. It combines the high altitude of a 300 kHz and high resolution of a 1200 kHz DVL in a single, easy to install navigation instrument.

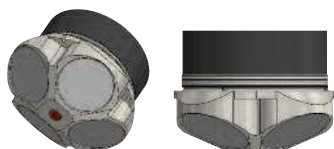

- Class-leading precision
- Current profiling option
- Easy to set up and use
- Reliable and adaptive bottom lock
- Replaceable transducers
- Water-blocked transducer array
- OEM options available



## TARGET TRACKING> MICRO-RANGER 2 / MINI-RANGER 2 / RANGER 2

When you need to invest in Ultra-Short BaseLine (USBL) acoustic technology to support your underwater operations, Micro-Ranger 2, Mini-Ranger 2, Ranger 2 and AvTrak 6 have the performance you need, at the investment level you can afford to track and command your divers and underwater assets.



- Track multiple underwater targets simultaneously
- Ranges in excess of 11 kilometres possible
- Fast position update rates, 3 per second
- Global record of success on all types of vessel
- Support available globally 24/7



## TARGET TRACKING> AVTRAK 6

With AvTrak 6, underwater drones can alter mission plans, provide health status updates and even share mission goals with other vehicles and underwater platforms operating nearby. AvTrak 6 is also compatible with the Sonardyne systems fitted to many vehicles and navy-owned research ships in service.



- 3-in-1 instrument: USBL transponder, LBL transceiver and acoustic modem
- Models to suit all vehicles sizes including XLUUVs
- Low power and easy to install
- Emergency relocation mode
- Depth options to 7,000 metres



## DEFENCE CAPABILITIES

# AT A GLANCE

### SITUATIONAL AWARENESS > NOAS

---

When your mission takes you into uncharted waters, our forward-looking sonar, NOAS, helps you see what lies ahead under the water and automatically warns of hidden dangers. Alerts based on depth, distance from the vessel and estimated time to impact can be configured to warn of potential grounding or hazards.



- Collision avoidance for vessels and manned underwater vehicles
- Detects seafloor and floating navigation hazards
- Up to 1,500 metres sonar range
- Retains history of vessel passage to assist with manoeuvring
- Optional diver detection security mode when anchored

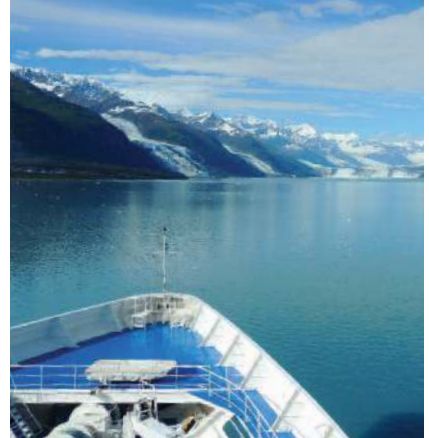

### ISR > FETCH / ACOUSTIC COMMUNICATIONS MODULE

---

Fetch supports the most demanding long-term seabed monitoring missions. Its 3,000 metre rated glass sphere housing can be supplied with a high capacity primary lithium battery pack to support deployments in excess of 10 years.



- Configurable with a wide range of standard and custom sensors including: sound velocity, temperature and depth
- Easy to deploy; lands upright on seabed
- Acoustic telemetry link enables data recovery on demand
- Integrated release mechanism for easy retrieval



### MCM AND HYDROGRAPHY > SOLSTICE

---

Solstice provides ultra-high resolution imagery for AUV mine detection and classification operations. Low power consumption and a wide swath results in long vehicle endurance and high area coverage rates.

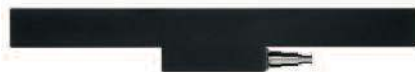

- Multi Aperture Sonar (MAS) suitable for low-logistic AUVs
- Suitable for Search, Classify and Map (SCM) operations
- Full dynamic focus and ultra-high along-track resolution best for CAD/CAC
- Provided with Interface Control Document for easy integration

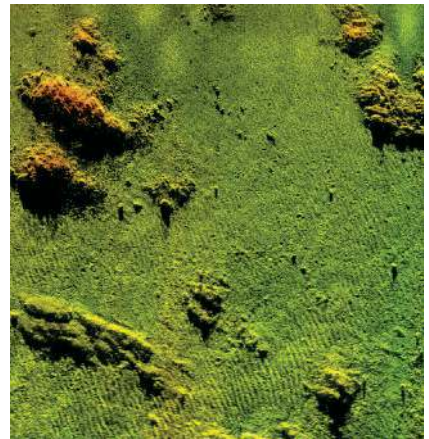

## SENSOR DEPLOYMENT AND RECOVERY> MODEM 6 / BLUECOMM

Modem 6 is a family of versatile acoustic modems built around trusted mechanics and Wideband 2 signal architectures. BlueComm optical modems deliver fast and efficient data recovery via AUV, ROV or USV-deployed dunker.



- Wideband 2 delivers robust performance in all environments
- Reliable, low-bandwidth, bi-directional communications
- Up to 500 Mbps data rate with BlueComm
- Energy efficient to maximise power budget
- Compatible with subsea Ethernet networks



## SENSOR DEPLOYMENT AND RECOVERY> RT 6

When you need a reliable acoustic release for long term equipment deployments, we can supply an RT 6 variant to work in environments ranging from littoral zones to the deep ocean. RT 6 can also be used to electrically activate equipment, such as mine lift bags.



- Depth options to 6,000 metres
- Can be tracked and commanded using Ranger 2 systems
- Long endurance; up to 4 years on alkaline batteries
- High Working Load Limit (WLL) capability
- Optional rope canister for hauling up equipment



## SUPPORT

# WE DESIGN WE ENGINEER WE INTEGRATE

**WITH HUNDREDS OF INSTRUMENTS SUCCESSFULLY DELIVERED AND INSTALLED, WE HAVE THE EXPERIENCE TO WORK SIDE-BY-SIDE WITH YOUR ENGINEERS, PRIME CONTRACTORS, SHIP'S COMPANY AND PLATFORM INTEGRATORS TO MAKE INVESTING IN AND COMMISSIONING SONARDYNE TECHNOLOGY IN YOUR NAVAL PROGRAMS SIMPLE AND STRAIGHT FORWARD. IT'S ALL PART OF THE SERVICE THAT HELPS LOWER YOUR OPERATIONAL RISK, EXTEND BUDGET FURTHER AND SPEED UP DEPLOYMENT OF NEW CAPABILITY.**

### EXPERT ADVICE

Our long-term partnerships with navies, research departments and maritime security agencies have enabled us to develop a unique and extensive insight into the diverse nature of naval operations. We understand that the technology investment decisions you make today will affect your capabilities for years to come, so they need to be right.

That's why you can trust our global commercial and technical teams to give you expert advice on which Sonardyne system is best for you, where and how it should be installed, what customisation it may need and the typical performance you can expect to see based on how and where you'll be using it. That's not forgetting extended warranties and through-life support packages.

### OPERATOR TRAINING

Making sure that you get the very best out of your Sonardyne technology – once it is installed and commissioned – is the goal of our operator training programme. From standard courses, run at our worldwide centres, to bespoke courses held at your facility or on board your vessel, our training is comprehensive and flexible.

### HELP WHEN YOU NEED IT

As a Sonardyne customer you gain unrivalled access to our care programme. A dedicated email helpline connects you to product engineers who are ready to answer your questions. If it's more urgent, our 24-hour worldwide telephone helpline is standing by, ready to resolve any operational issues you're facing.







## SUBSEA TECHNOLOGY

### Global Headquarters

T. +44 (0) 1252 872288  
F. +44 (0) 1252 876100  
sales@sonardyne.com

### Singapore

T. +65 6542 1911  
F. +65 6542 6937  
asia.sales@sonardyne.com

### Aberdeen, UK

T. +44 (0) 1224 707875  
F. +44 (0) 1224 707876  
sales@sonardyne.com

### Rio das Ostras, Brasil

T. +55 22 2123 4950  
F. +55 22 2123 4951  
brasil.sales@sonardyne.com

### Houston, USA

T. +1 281 890 2120  
F. +1 281 890 7047  
usa.sales@sonardyne.com

### 24 Hour Emergency Telephone Helpline

T. +44 (0) 1252 877600  
support@sonardyne.com

SONARDYNE.COM

