

Datasheet

Lodestar 300 OEM AHRS / SPRINT 300 OEM AAINS



Description

Lodestar 300 OEM is a solid state Attitude and Heading Reference System (AHRS). SPRINT 300 OEM is a combined solid state AHRS and an Acoustically Aided Inertial Navigation System (AAINS).

SPRINT has a proven track record spanning 10 years in the field including subsea vehicle guidance and autopilot to demanding survey applications. The on-board sensors are 'the' standard for commercial aviation with a proven 15+ year track record.

Lodestar AHRS requires no external aiding and can settle in 5 minutes or less in dynamic conditions while the SPRINT INS adds advanced Aided Inertial Navigation that runs concurrently with the AHRS algorithm.

This dual algorithm capability is unique in the market and allows for automatic on-board integrity checking between both orientation solutions. Furthermore, the SPRINT INS algorithm can instantaneously start with North alignment from the on-board AHRS. This negates the need for particular dynamics to 'align' standalone INS products to North.

SPRINT INS supports a wide range of aiding including USBL, Depth, DVL, Zero Velocity, Manual Position, LBL Position and GNSS to support most autonomous vehicle requirements. Optimal tight coupling is supported for Sonardyne's Syrinx and 6G LBL acoustics products, also available in OEM form.

On-board data storage allows for post-mission diagnostics checking with the supplied Janus QC software. Optional SW upgrade allows for reprocessing and optimisation of the navigation solution.

The unit is provided in lightweight aluminium housing and is one of the smallest form factor high performance OEM INS/AHRS units available.

Sonardyne provides a dedicated integration development kit and service for Lodestar/SPRINT OEM.

Applications Include

- Any subsea autonomous platform including AUV, AIV, ROV, Towfish and ROTV
- Manned submersibles
- Surface autonomous vehicles (ASV)

Key Features

- Single box OEM solution for AHRS or AHRS & AAINS
- Development kit included
- Integration service with on-site or remote engineers
- SPRINT provides concurrent AHRS and AAINS capability for auto-integrity checking & instantaneous INS start and alignment
- 0.2° (Lodestar) to 0.05° (SPRINT) secant latitude heading accuracy
- 0.01° roll and pitch accuracy
- <15 minute AHRS settling time
- Fast follow up speed of 900°/sec
- MTBF inertial sensors (RLG and Accelerometer) > 400,000 hours
- Lightweight aluminium housing
- Molex connectors
- Transport approved rechargeable li-ion battery back-up option
- Minimum internal memory of 8 GB allows post processing and remote diagnostics
- Ethernet interface available
- Lodestar AHRS can be remotely upgraded to SPRINT INS

Specifications

Lodestar 300 OEM AHRS / SPRINT 300 OEM AAINS

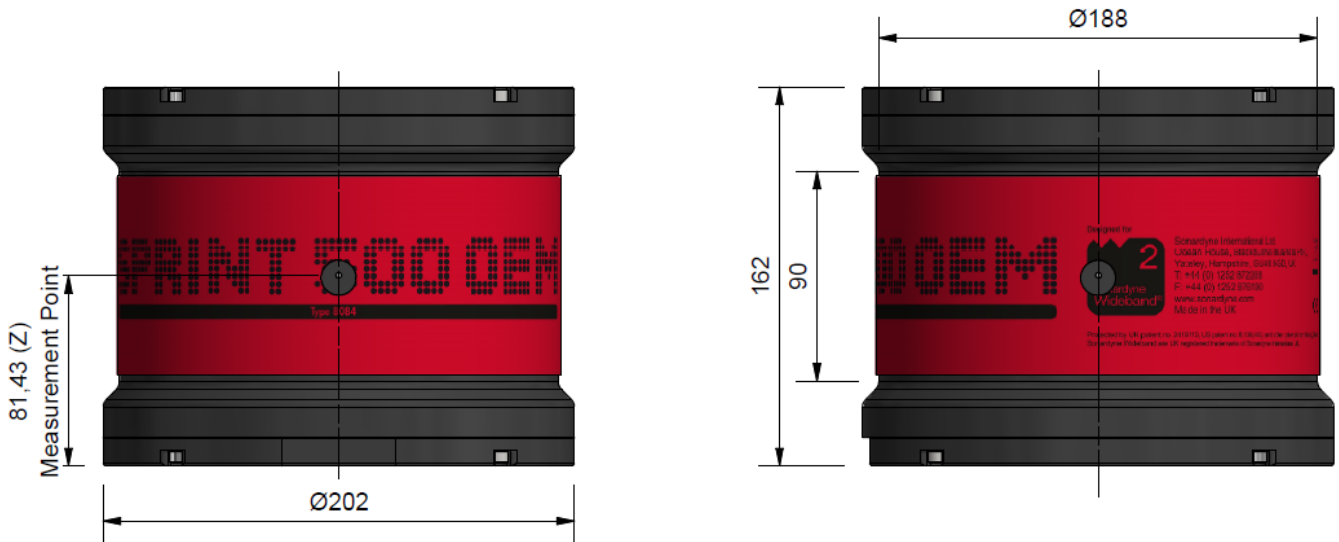

Feature	Type 8084-000-9911	
Performance	Heading Accuracy	0.2° (Lodestar AHRS), 0.05° (SPRINT INS) Secant Latitude
	Roll and Pitch Accuracy	0.01°
	Settle Time	<15 minutes in dynamic conditions (AHRS), Instantaneous (INS)
	INS Aiding Supported	USBL, Depth, DVL, Zero Velocity, Manual Position, LBL (position), GNSS
	USBL/LBL Aided	3 x precision improvement over USBL/LBL (Position)
	USBL/LBL and DVL Aided	3 to 7 x precision improvement over USBL/LBL (Position)
	DVL Aided Accuracy	0.2% position error for distance travelled (3 rd party DVL) 0.12% position error for distance travelled (Sonardyne Syrinx DVL)
	DVL Aiding Loss/Drift	1.2 m over 1 min, 5 m over 2 mins (CEP50)
	Station Keeping	<1 m over 1 hour (3 rd party DVL) <1 m over 24 hours (Sonardyne Syrinx DVL)
Upgrades	Lodestar 300 AHRS can be remotely upgraded to SPRINT 300 INS	
Power	Power Requirement	24 / 48 V DC, 15 W nominal (35 W max with optional external battery)
	Back Up Battery Type / Life**	Li-ion / 5 minutes (optional)
Data / Comms.	Data Storage	8 GB internal memory
	Digital Ports/Protocol	up to 4 digital Ports / RS232 or RS485
	Other Ports	1 x Ethernet, 4 Triggers
	Output Rate	Up to 100 Hz
	Output Telegrams*	Industry standard AHRS/INS telegrams including acceleration and rotation rates
Environmental	Operating Temperature Range	-20 to +55°C
	Storage Temperature Range	-20 to +60°C
	Shock Rating	22 g, 11 ms half sine
Physical	Mechanical Construction	Aluminium
	Connectors	5 x Molex
	Dimensions (Diameter x Height)	Ø202 x 162 mm
	Weight in Air***	7.8 kg

*Specific outputs may be limited below quoted performance for reasons of export classification and control and should not be used as IMU data.

**Optional Back-Up Battery Available

***Estimated Weights